



Modifying the RX320 Receiver for LF/VLF Operation

BACKGROUND

The RX320 has gotten a lot of enthusiasm from users and reviewers for its cost vs. performance on the HF bands. It is rated down to 100 kHz but performance below 500 kHz suffers and at 100 kHz it becomes very insensitive. This is true for the external antenna input as well as for the built-in active whip antenna. As part of the effort to develop LF technology for amateurs in anticipation of FCC allocations to U.S. amateurs, the RX320 was examined as a potential low cost LF receiver for these amateur operations.

Based on our work on receiving antennas, the built-in active antenna simply cannot meet the performance needed for even marginal use. We therefore concentrated on the external antenna input to be fed by an optimized LF active antenna placed far away from sources of interference such as computers and their monitors.

Our examination of the schematic available for download on the TenTec web site <http://www.tentec.com> revealed that the external input signal was routed through a series of inductors L22, L23, L24 and L25 making up a low pass filter to reject the first IF frequency. From there the signal enters a high-performance mixer circuit through T3. T3 is constructed from a binocular ferrite core and several turns of trifilar wire. It turns out that the primary of this transformer has only 50 ohms of inductive reactance at 550 kHz. This will result in signal loss in a 50-ohm system starting at this frequency with increasing losses at lower frequencies. By 100 kHz the losses are almost 15 dB.

Our objective was to replace T3 with an improved wideband transformer that would extend the response down to 10 kHz while retaining HF performance out to 30 MHz. The main source of reduced performance at 30 MHz would come from transformer leakage reactance.

MEASUREMENTS AND TESTS

A test transformer was constructed and tested. After several adjustments we had a design that had a measured 50 ohm primary reactance at 10 kHz. Leakage reactance was more difficult to measure but with some effort a test setup revealed the leakage reactance was 50 ohms at 30 MHz. Leakage reactance was measured by short circuiting the secondary windings and measuring the input impedance with a Hewlett Packard 803A impedance bridge. For this value little if any degradation will be observed up to 30 MHz.

The transformer was installed and LF and VLF performance was greatly improved with an outdoor active LF/VLF antenna. No HF degradation was detected but a side by side test would be the best way to judge this. AMRAD member Bill, W3CXS had an unmodified RX320. He agreed to help conduct a side by side test. It was conducted on a number of frequencies on a number of signals. A quantitative test was run at 29.5 MHz. We were both experienced weak signal CW operators so a minimum detectable signal test was run. In this test a signal generator was reduced in level until it was no longer heard by common agreement. The RX320s were run in the 300 Hz bandwidth. A fixed attenuator in addition to the signal generator attenuator gave enough attenuation that the signal could be made to disappear. The result was that the modified receiver minimum detectable signal of -147 dBm was slightly lower than the unmodified one of -144 dBm. We had not expected this improvement and it may be due to unit to unit variation rather than an actual improvement.

MODIFICATION

The new transformer is constructed on an Amidon FT50-75 or FT50-J ferrite toroid core. It is wound with 16 turns of trifilar wire. The trifilar wire can be constructed out of 3 lengths of #30 wire wrap wire twisted together. They should be about 2 feet long and twisted together with about 2 twists per inch. This wire is commonly available from Radio Shack in small spools of different colors. Using the different colors helps to keep track of each of the windings. Once wound, the windings should be secured. This can be done with a drop of hot glue from a hot glue gun. The leads should be stripped close to the toroid with 1 inch of lead length.

The RF (top) printed circuit board should be removed from the chassis for the modification. Note the connectors and the polarities for re-assembly as they can be reversed. T3 should be removed from the RF board. Note the direction it is in the board, as you will need to refer to it for connection. You will need to do this with a good temperature controlled soldering iron and a solder sucker. This transformer has six leads and all need to be freed before the transformer can be removed.

WARNING: This part of the modification requires considerable soldering skill and should not be attempted if you feel unsure of this step. If you have never removed a 14 or 16 pin DIP IC intact you probably don't have the equipment and experience needed to remove the original transformer intact. If you are comfortable destroying the original transformer header, less sophisticated tools will suffice. If not find a friend who has the equipment and skills needed.

The transformer connection is not quite obvious. Note that the original transformer windings have different colored leads for each of the three windings. One winding has each end connected to pins across from each other. The other two windings have the leads crossed going to the pins on the header. The new transformer connects just like the original transformer. [Figure 1](#) illustrates how the leads are reconnected to the PC board with pin numbering similar to DIP numbering. Note that the primary leads which are not crossed go into the two transformer holes facing towards the front or the antenna post.

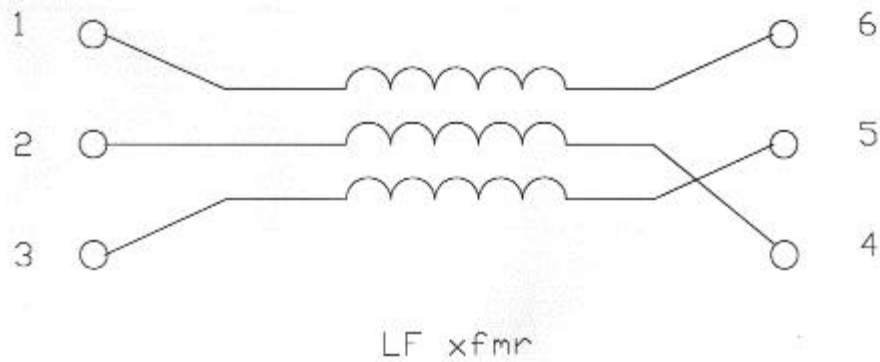

Figure 1

After the transformer is installed and testing shows it is working properly the transformer can be secured to the PC board with a drop of hot glue from a hot glue gun. Other adhesives should also be satisfactory but this worked well. [Figure 2](#) shows the RF PC board after modification and the new transformer hot glued to the board.

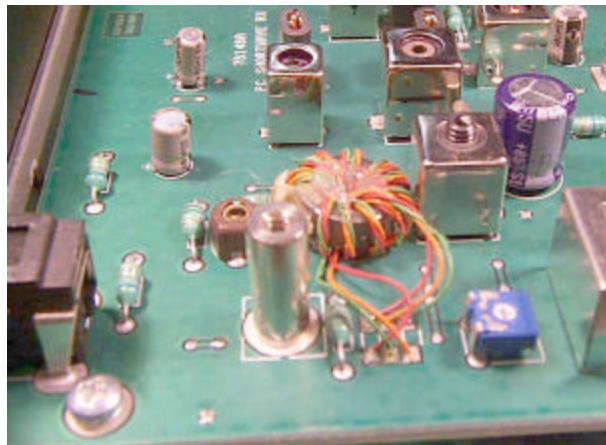
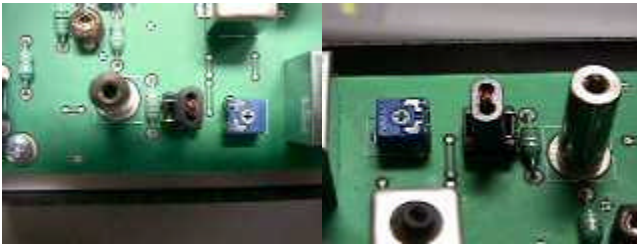

Figure 2

For a step-by-step photo tour of the modification we have pictures courtesy of Larry Putman. Larry did this modification without seeing mine.

First, locate the transformer T3 that you will remove.



Locate the solder pads on the bottom of the PC board, here before and after.



And this is the transformer you should have removed.



And now install the new transformer and it looks like this.



Here is another view of another installation by Hugh, K4KIN done like Larry, from the instructions alone.



AGC MODIFICATION

Once the receiver is modified to go down to LF the AGC becomes a problem. Two approaches have worked. First is to insert a variable attenuator in the antenna line. The second approach was worked out by Bob Johansen, WB2SRF. Bob's modification has been tried here and it works well to overcome the tendency of the AGC to overshoot on impulse noise. Here are Bob's Modification Instructions.

Ten Tec RX-320 LF Modifications

Bob Johansen WB2SRF

Disclaimer: The following technical information is provided solely under the condition that the user understands that modifications improperly performed may damage the equipment and/or void the manufacturer's warranty and that this does not obligate the author in any manner.

The Ten Tec RX-320 Receiver is an excellent performing short wave receiver. It features a DSP 3rd I.F filter with 34 different selectable bandwidth filters with excellent shape factors available to enhance the reception of signals under varying conditions. It competes favorably with more expensive receivers. The capability of this receiver can be easily extended down to VLF by performing several modifications.

The unmodified receiver tunes from 1-30 MHz at a sensitivity of less than 1 micro Volt. The sensitivity is intentionally reduced below 1 MHz to prevent strong local AM broadcast stations from overloading the front end of the receiver as this can cause IMD (Inter-modulation Distortion) products to appear.

The RF transformer and BCB trap, high pass filter bypass switch modifications will greatly improve the sensitivity of the receiver down to 20 KHz. However, it was found that the RF AGC pumps badly on LF noise.

The addition of the manual RF Attenuation control stops the pumping action by setting an AGC threshold; the existing AGC can still add more attenuation above this threshold if needed.

The potentiometer (manual RF attenuation control) sets the bias of the PIN diodes in the analog RF AGC circuit to prevent distortion from occurring in the front end of the receiver. This acts like an RF gain control and provides up to 40 dB of attenuation to the received signal. When this control is advanced to apply the threshold bias of 0.5V or more to the PIN diodes, it improves the fidelity of strong AM signals by lowering the distortion caused by the AGC circuit attempting to reduce the gain following the modulation peaks of the received signal. The original AGC circuit can still override the manual control on very strong signals because the 1N914 diode will then be reverse biased.

- 1) Replace the RF input transformer by following AMRAD "Modifying the RX320 Receiver for LF/VLF Operation"
- 2) Follow the attached schematic and add the components to the receiver as shown below.
- 3) Install a small SPST switch on the rear panel, mount it close to the Antenna Jack. Keep the connecting leads as short as possible.
- 4) Install a small 1K Ohm potentiometer on the upper center of the rear panel to the left of the Antenna Jack. Connect the cathode of the 1N914 diode to the AGC via on the RF board. This can be easily done by looking at the back of the RF board (end closest to the receiver's back panel to the left of C109 adjustable trimmer capacitor part of the 45 MHz trap there is a coil L25 (0.1uH) just to the left of this coil is the AGC circuit via).
- 5) When using the receiver at LF it is recommended that a BCB (0.6-1.6 MHz) rejection filter, pre-selector or tuned loop antenna be connected to the receiver's external Antenna Jack otherwise strong AM BCB stations will appear. Set the Attenuation control to keep the S-meter at a maximum peak signal level of 70 dB for the best performance.
- 6) To restore normal operation of the receiver keep the attenuation control set fully counterclockwise and set the LF switch to the off position.

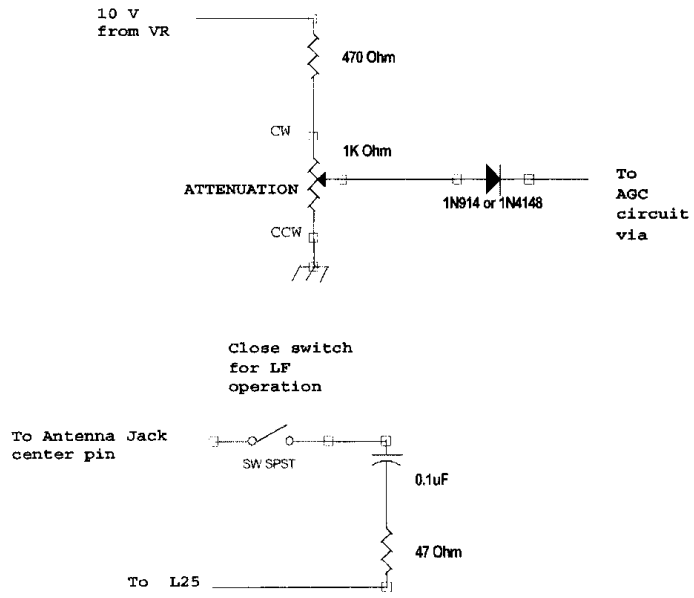

The resulting AGC modification looks like this.

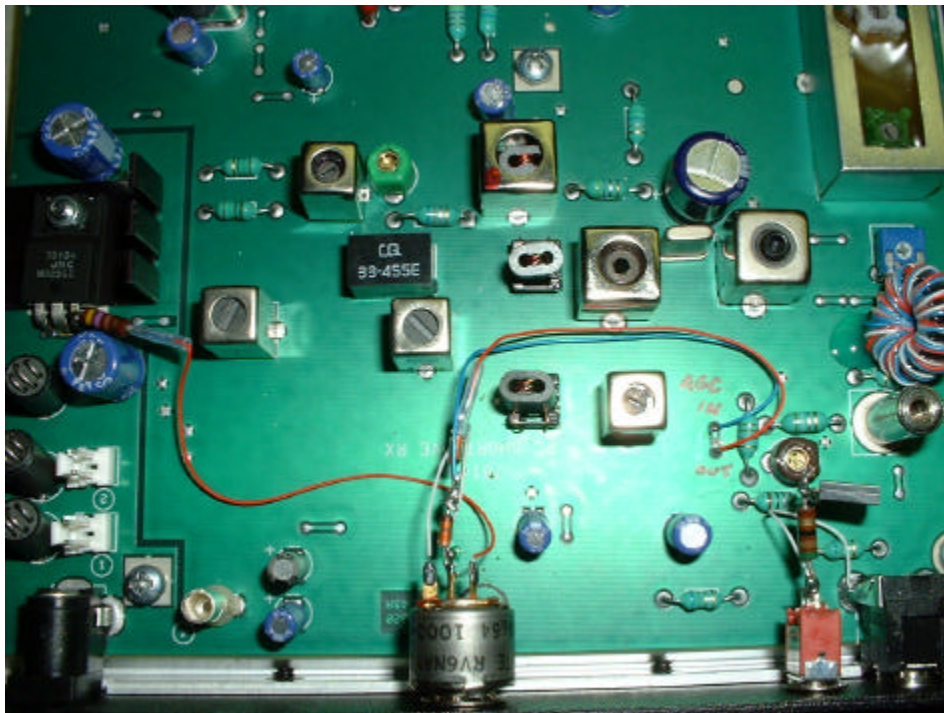

RESULTS

The TenTec software works right on down to 10 kHz but rejects storing and recalling frequencies below 100 kHz. The built-in active antenna could be modified to go down lower in frequency but would make the FET input stage more susceptible to static discharge. We left this stage unmodified and instead used an outdoor antenna that includes an isolation transformer that keeps power line currents from flowing along the antenna coax and corrupting the signal. With this said, it may be the subject of a future modification if the FET can be protected because it would be handy to have it all self contained.

For LF listening the use of an active e-field probe or active loop will bring the listener a lot of marginal signals that wire antennas will not. A 60 or so foot wire that works fine at HF or in the MF broadcast band will seem very insensitive at LF. The weak 60 foot wire will seem deaf at 24 kHz on VLF. Note that the input impedance of the RX320 after modification is still 50 ohms right on down to 10 kHz while wire antennas will rise in impedance as their wavelength gets ever shorter and shorter at decreasing frequency. In addition, we have found the need for an isolation transformer to control the introduction of AC powerline harmonics into the signal output of the antenna. In most situations, the powerline harmonics should be gone and LF should sound like the 2 or 3 MHz bands.

Using the RX-320 side by side with an NRD-525 shows a nearly equal comparison with the 200 Hz CW filter installed in the NRD-525. On very marginal MSK signals at VLF the presence of the signal could be heard on the NRD-525 and not on the RX-320. Below 20 kHz the first local oscillator feeds through the first IF filter and desensitizes the receiver. This desensitization is obvious as you go down through 13 kHz you will notice a pronounced reduction at one point in sensitivity as the first LO shifts into the passband of the first IF filter.

Using the TenTec, Gerd Niephaus <http://gniephaus.tripod.com> software with the modified RX-320 on LF is a pleasure. Gerd Niephaus' software works down to 10 kHz if you edit the file Gnrx320.ini in the C:/WINDOWS directory to add the line "MinimumFrequency=10000" under the [Configuration] section.

You can jump from HF to LF to check conditions and back again just by having a few LF frequencies preset in the software. My active antenna goes from 10 kHz to 30 MHz so no antenna switching is needed. The slow AGC option helps CW performance and is available from the KF50J program but not the TenTec program. You can get the slow AGC in the TenTec program by setting the AGC speed in the KF50J program, exiting and entering the TenTec

program. It looks like the TenTec program does not attempt to set AGC speed so it defaults to the last value in the RX-320.

But now even more exciting things are in store if you combine a spectrum display program like [Spectran or Argo](#) and follow Bill Farmer's [calibration procedure](#). You can identify LF spectral lines to within one Hz or so. For weak signals like LOWFers this is very useful to aid in identification. Recent experience using this has shown the combination of the RX320 LF modified and Spectran to be a big step forward in weak signal work over simple narrowband CW filters.

Frank Gentges K0BRA

Updated 24 November, 2002